

NanoSensors®

Technical Guide



NanoSensor® for the ultimate in position monitoring

This guide gives a step by step process to select a Queensgate NanoSensor®.

The NanoSensor® is a non-contact position measuring system based on the principle of capacitance micrometry. Two sensor plates, a Target and a Probe, form a parallel plate capacitor. The spacing of these two plates can be measured using an appropriate electronic controller. Resolutions as small as 7 picometres (RMS) can be achieved. Measurement ranges from 20µm up to 11mm are available with our standard products with frequency responses up to 5KHz and linearity down to 0.02%.

Suggested controllers

The NS2000 or the NS-A-4101 are single channel standalone electronic modules for driving the NX NanoSensor® series. Either controller can be synchronised to allowing multiple units to be operated together without interference.

The sensor controllers operate by measuring the change in capacitance of a parallel plate capacitor and output an analogue voltage proportional to the NanoSensor gap.

- Precision measurement to picometres
- Stability of measurement
- Tuneable to meet application needs
- Options for a wide range of applications

Typical applications

- Precision manufacturing
- Metrology
- Deformation measurements
- Strain measurement (used on space station robotic arm and hand)
- Stage control
- Materials testing
- Microscopy
- Active Optics
- Precision Beam Steering

Key benefits

- No power is dissipated at the point of measurement
- Very sensitive to atomic scale changes in position
- Repeatable measurement
- High Accuracy
- Allows optimisation to give either positional accuracy or high responsiveness to dynamic motion.
- Choice of materials to minimise position drift.
- To suit a broad range of environmental challenges

NanoSensors®

Technical Guide

Using the NanoSensor®

The two plates of a NanoSensor® are mounted facing each other with an air gap (G) equal to the measuring range. One plate is secured to a fixed reference, the other secured to the moving part to be measured. The sensor measures displacement over the region 0.5G to 1.5G, for example a 100µm range sensor is mounted with a 100µm nominal gap and operates from 50µm to 150µm. For the best linearity the sensor faces should be mounted parallel to each other.

Each sensor can be used over two different measuring ranges denoted -L for long range and -S for short range, with 2pF and 10pF capacitances respectively. For example the NXC sensor can be used to measure a 500µm range with a noise level of 75pm rms Hz^{-1/2} or to measure a 100µm range with a noise level of 5pm rms Hz^{-1/2}. The -L or -S operation is determined by the electronic controller and is user selectable. The measurement bandwidth is also user selectable at 50Hz, 500Hz or 5kHz.

Choosing a NanoSensor®

Step 1: Range Selection

When choosing your NanoSensor® first select a size to meet your range requirements. Sensors will give higher resolution when used on a short range (High capacitance setting) so this is preferable for the best performance. This means that where there is a choice of two sensors for the same range the larger with give lower noise. For the highest linearity choose a large gap sensor and measure over a small part of the full range. For example using NXC2-L sensor over 100um of the 500um calibrated range will give <0.005% linearity. Where space is limited a smaller sensor can be selected and used at a lower capacitance (XL setting) this gives a larger range from the same sensor area. Sizes B to D are standard products, E to G are available as custom solutions.

Sensor Range um (microns)						
	Standard switch between (L or S primary range)		Option 1 (XL or ML Primary range)		Option 2 (MS or XS primary range)	
	2pF (L)	10pF (S)	1pF (XL)	5pF (ML)	4pF (MS)	20pF (XS)
B	100	20	200	40	50	NCA
C	500	100	1000	200	250	50
D	1250	250	2500	500	625	125
E	2000	400	4000	800	1000	200
F	5000	1000	10000	2000	2500	500
G	11000	2200	NCA	4400	5500	1100

Step 2: Bandwidth frequency selection

The bandwidth should be selected based on the application. Where accuracy of position is being monitored a slow bandwidth (eg 50Hz) will give the highest resolution. Where vibration or higher frequency position is being monitored (dynamic measurement) bandwidths should be set at a higher frequency than the frequency being measured. Depending on the accuracy of the waveform required this can be at least 2 to 10 times the measured frequency.

Step 3: Position resolution

Standard range sensor resolutions have been determined below.

The range (L or S) and bandwidth (50, 500, 5000Hz) is user selectable (NS2000 series). A primary range is used for calibration; this will have the best linearity and the lowest scale factor error. The other range setting will typically be linear to 0.1%.

Typical resolution nm rms (Range um) – with NS-2000 controller						
	Low Bandwidth (50Hz)		Medium Bandwidth (500Hz)		High Bandwidth (5000Hz)	
	L (2pF)	S (10pF)	L (2pF)	S (10pF)	L (2pF)	S (10pF)
B	0.106 (100)	0.007 (20)	0.335 (100)	0.022 (20)	1.061 (100)	0.071 (20)
C	0.530 (500)	0.035 (100)	1.677 (500)	0.112 (100)	5.303 (500)	0.354 (100)
D	1.329 (1250)	0.092 (250)	4.204 (1250)	0.291 (250)	13.294 (1250)	0.919 (250)
E	2.222 (2000)	0.160 (400)	7.027 (2000)	0.506 (400)	22.222 (2000)	1.600 (400)
F	5.556 (5000)	0.400 (1000)	17.568 (5000)	1.265 (1000)	55.556 (5000)	4.000 (1000)
G	12.222 (11000)	0.880 (2200)	38.650 (11000)	2.783 (2200)	122.222 (11000)	8.800 (2200)

Sizes B to D are standard products, E to G are available as custom solutions

NanoSensors®

Technical Guide

Step 4: Linearity and scale factor error

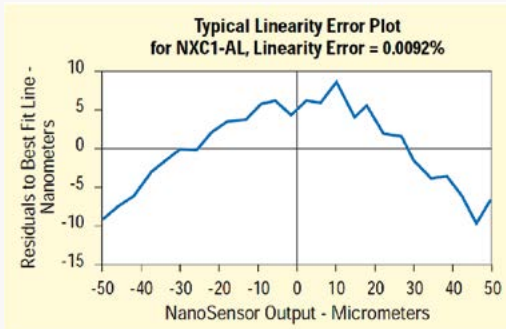

The graph shows the linearity error of a NXC2-AL sensor, in this example it is <0.01%. This is achieved without electronic compensation. Below 0.1%, linearity error is dominated by the parallelism of the mounting surfaces. For the highest linearity choose a large gap sensor and measure over a small part of the full range. For example using NXC2-L sensor over 100um of the 500um calibrated range will give <0.005% linearity.

Linearity error and tilt

The NanoSensors® performance is not very sensitive to tilt. However for the smallest linearity error the parallelism of the plates needs to be better than 2mrad. Note for a given tolerance the effect of the tilt is lower when the gap (range) is larger.

Scale factor error and tilt

The scale factor is also affected by the parallelism of the plates. A tilt of one mrad causes a 0.5% change in scale factor. The graph is a plot for the 100um range sensor, longer range sensors are much less sensitive to drift.

range will be double the standard long range 2pF setting.

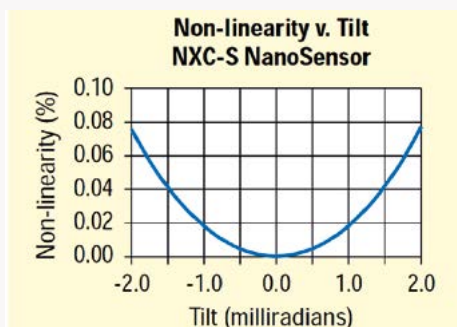
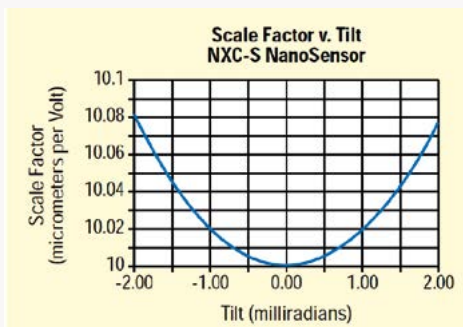

Step 5: Material selection

The material should be selected based on the application. Sensor thermal drift is independent of control electronics drift which is a property of a controller and its environment. The capacitive sensors thermal drift is due to thickness and area changes created as the material changes size with temperature. The change in thickness usually dominates the thermal position drift. The effects can easily be calculated using the coefficients of thermal expansion of the material. In some applications it is best to match the thermal expansion to one which is similar to the surrounding structure. For example in a mechanical structure such as a light microscope, where the critical parts are all constructed of aluminium. In this situation it is often best to use aluminium sensors as this will match best the structural expansion. Aluminium sensors are also more cost effective typically being half the cost of super invar.

For some applications low magnetism may also be critical requirement when operating near powerful magnets or near magnetism sensitive equipment. For these applications aluminium should be selected. Ceramic sensors are also available for custom applications providing a radiation hard, UHV, cryogenic solution which is non magnetic

	Coefficient of Thermal Expansion (CTE) (0 to 50oC)	Magnetic
Aluminium (6061)	22	No
Super Invar (32-5)	0.15	Yes

NanoSensors® Technical Guide

Step 6: Vacuum, radiation and cryogenic compatibility

UHV NanoSensors® are available. They are constructed of materials which have very low outgassing including Kapton insulated wires. Parts are also ultrasonically cleaned and baked. The NX and NZ series are suitable for vacuums as low as 10⁻⁹ torr and the NC series are suitable for vacuums as low as 10⁻¹⁰ torr. Due to the UHV compatible cables UHV model sensors do have increased position noise. If we can quantify this it would be better.

Some UHV model sensors are also radiation hard (RAD) these are designed for 107 Gy (109 Rad). The NC series is available with a RAD hard option.

While most of the NanoSensors® ranges are fully functional at cryogenic temperatures the NC series is designed for the best performance at these temperatures.

Step 7: Cable Length

Standard cable length is 1m for most sensor models. Maximum cable length will depend on the setup selected, however standard NX NanoSensors® with the NS2000 series controller can operate with up to 10 meters of air cable. It should be noted that specifications refer to 1m cables.

Airside cables to go with UHV systems and standard extension cables are also available.

Pre – amplifiers for custom applications requiring longer cables may be use with multichannel custom controller models.

Step 8: Model and shape

There are several things to consider when selecting your NanoSensor® ; sensor area, shape/form, material, cost, vacuum compatibility and radiation compatibility.

NX Series

The NX series are metal construction sensors available as standard in Aluminium (6061) or Super Invar (32-5). Aluminium being the lower cost option and Super Invar offering the best thermal stability. The table below shows that standard options.

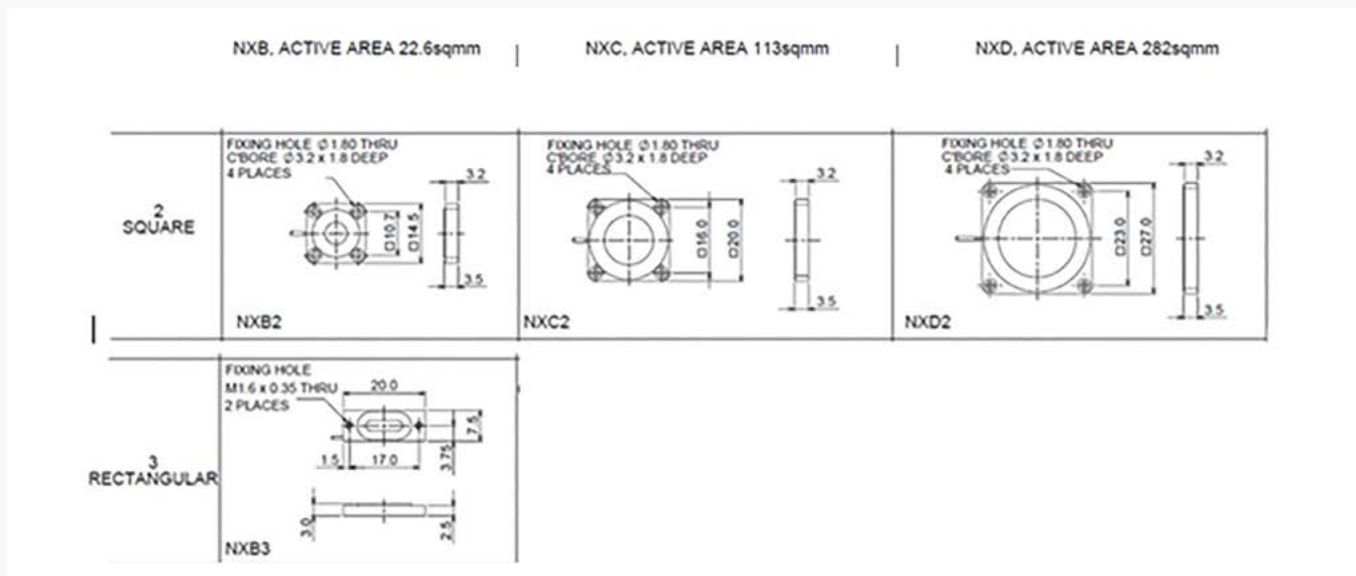

UHV variants are typically good down to 10⁻⁹Torr and can be baked out at up to 100°C for two days prior to installation.
Custom Sensors

Custom Sensors can be designed, please contact Queensgate to discuss specific applications. These include:

Custom sensors with other sizes, shapes and materials examples of such variants are included below.

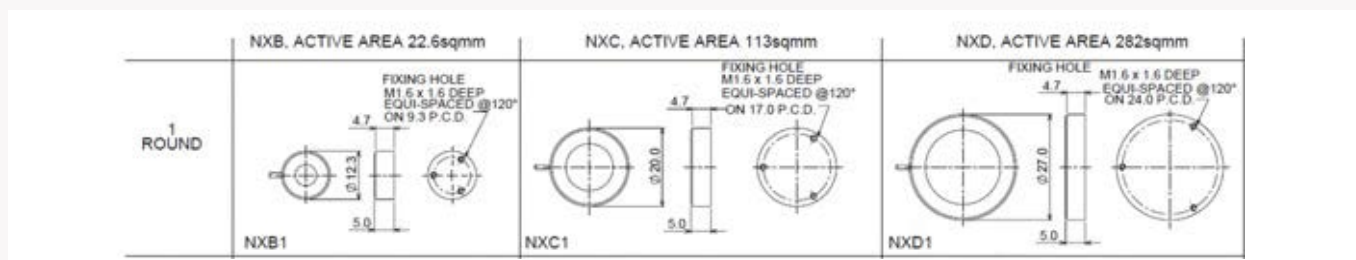

NanoSensors® Technical Guide

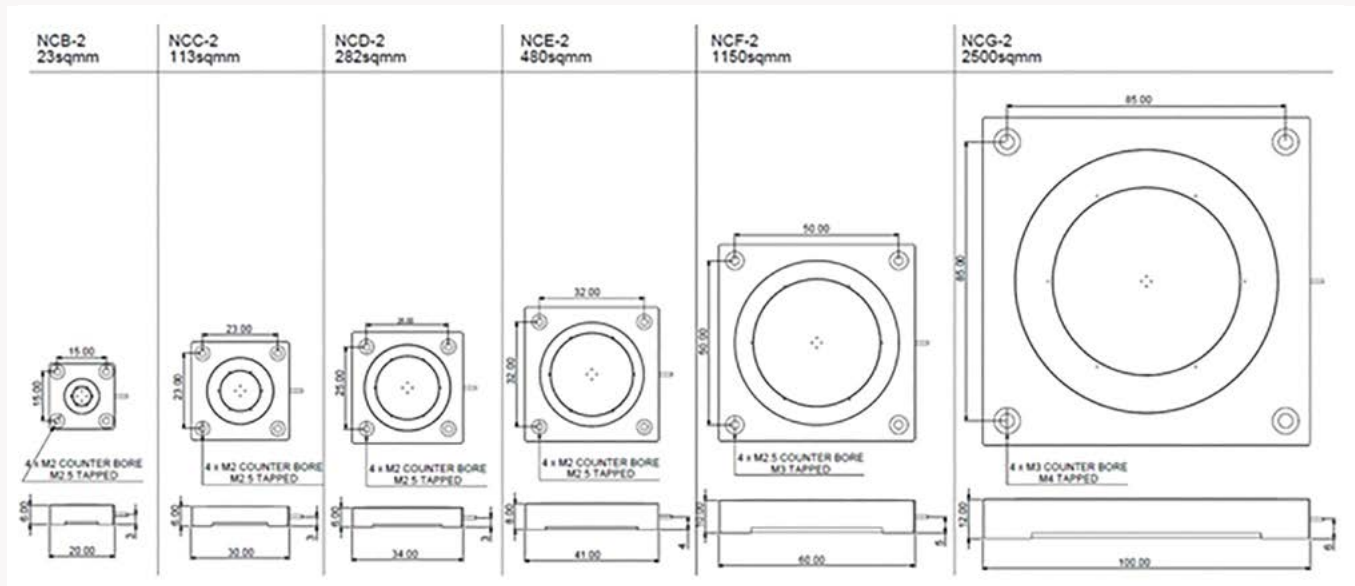

Typically good to 10^{-10} Torr and can be baked out at up to 180°C for two days. Other shapes can be produced on request.

NCG-1-AL-UHV

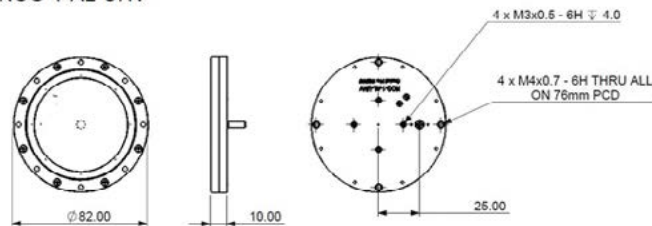

Typically good to 10^{-10} Torr they can be baked out at up to 180°C for two days.

This model has a second set of mounting holes specially designed to allow the mounting of a metal bellow to screen the sensor from electrical interference in very noisy environments. This model is designed to operate on the long range L setting.

Mounting NanoSensors®

As discussed earlier NanoSensors® performance is partly dependent of the setup of the parallelism and gap. When sensor gap and parallelism cannot easily be achieved within mechanical tolerances of the installation, an adjustment mechanism will help. The image shows one way of achieving this adjustment.

Handling Nanosensors®

Nanosensors® are manufactured to very high precision. As such they should be handled with care to avoid damage that may impact their performance.

Cabling should be handled with care, they should not be pulled or bent excessively as this can cause permanent damage. Cables should not be over restrained in operation.

Sensors should only be mounted using their screw or magnetic fixings.

Screws should be evenly torqued with a torque screwdriver, do not exceed the stated torque for mounting.

Sensors should be handled with gloves to avoid contamination especially for vacuum models.

Sensors can be cleaned with Iso-propanol and a lint free cloth (Consult your local organisations health and safety procedures). Avoid running the sensor cables and position output cables near sources of electrical noise (mains cables etc). For best performance ensure sensors, controllers and feed-through (UHV) are grounded.

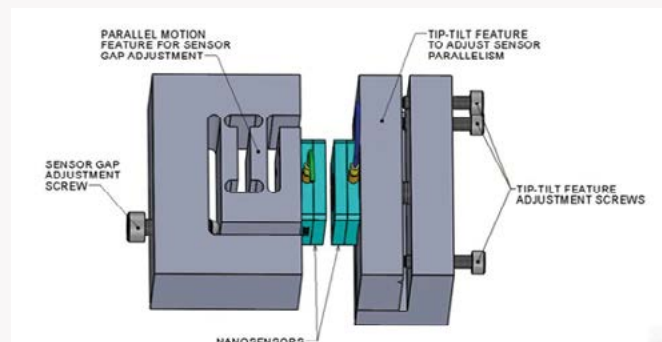

NanoSensors – NX Series Nanopositioning Sensors

Ordering information - NX Series Capacitive Sensors for Distance Measurement

Select the Sensor with an Appropriate Range:

PART	DESCRIPTION	MATERIAL
QGNXB2-AL	Square sensor pair - low cost (Range S = 20um L = 100um) 1m cable Lemo connectors	Aluminum
QGNXB3-AL	Rectangle sensor pair - low cost (Range S = 20um L = 100um) 1m cable Lemo connectors	Aluminum
QGNXC2-AL	Square sensor pair - low cost (Range S = 100um L = 500um) 1m cable Lemo connectors	Aluminum
QGNXD2-AL	Square sensor pair - low cost (Range S = 250um L = 1250um) 1m cable Lemo connectors	Aluminum
QGNXB2-SI	Square sensor pair - low cost (Range S = 20um L = 100um) 1m cable Lemo connectors	Super Invar
QGNXC2-SI	Square sensor pair - low cost (Range S = 100um L = 500um) 1m cable Lemo connectors	Super Invar
QGNXD2-SI	Square sensor pair - low cost (Range S = 250um L = 1250um) 1m cable Lemo connectors	Super Invar

Custom capacitive sensors are available on application in alternative shapes, Super Invar or ceramic with white gold plating.

Select the Sensor Controller:

PART	DESCRIPTION
QGNS-A-4101	Single channel controller, factory selectable bandwidths 100/1000/10000Hz and synchronization. Low noise analogue output. Long cable drive capabilities.

Ordering information - NX Series Ultra High Vacuum (UHV) Capacitive Sensor Systems

Select the Sensor with an Appropriate Range:

PART	DESCRIPTION	MATERIAL
QGNXB2-AL-UHV	UHV square sensor pair - low cost (Range S = 20um L = 100um) 1m Kapton cable SMA connectors	Aluminum
QGNXC2-AL-UHV	UHV square sensor pair - low cost (Range S = 100um L = 500um) 1m Kapton cable SMA connectors	Aluminum
QGNXD2-AL-UHV	UHV square sensor pair - low cost (Range S = 250um L = 1250um) 1m Kapton cable SMA connectors	Aluminum
QGNXB2-SI-UHV	UHV square sensor pair - low cost (Range S = 20um L = 100um) 1m Kapton cable SMA connectors	Super Invar
QGNXC2-SI-UHV	UHV square sensor pair - low cost (Range S = 100um L = 500um) 1m Kapton cable SMA connectors	Super Invar
QGNXD2-SI-UHV	UHV square sensor pair - low cost (Range S = 250um L = 1250um) 1m Kapton cable SMA connectors	Super Invar

Select the Sensor Controller:

PART	DESCRIPTION
QGNS-A-4101	Single channel controller, factory selectable bandwidths 100/1000/10000Hz and synchronization. Low noise analogue output. Long cable drive capabilities.

Select an Airside Cable:

PART	DESCRIPTION
QG2SMA-LEMO-1	1m air side sensor 2 x SMA to 2 x Lemo
QG2SMA-LEMO-2	2m air side sensor 2 x SMA to 2 x Lemo
QG2SMA-LEMO-5	5m air side sensor 2 x SMA to 2 x Lemo

Feedthrough for Capacitive Sensors:

PART	DESCRIPTION
QG242-SMADF50-C40-2	UHV feedthrough 2 x floating SMA DN-40CF (1 channel sensor RAD HARD

Custom capacitive sensors are available on application in alternative shapes, Super Invar or ceramic with white gold plating.

