

SP-Mini-500

Ultra-compact long-range piezo stage

The SP-MINI-500 is an ultra-compact, long-range piezo stage which moves 500µm in closed loop. Designed with OEM and customization projects in mind, its small footprint is ideal for easy integration within instrumentation or test equipment. The built-in capacitive positioning sensors enable ultra-high speed performance and low nanometer-level repeatability.

The stage has very low error motions, maintaining a very flat platform over its full 500µm travel range. This allows the sample holder to be offset, improving access to the sample whilst maintaining high performance positioning. Sample holders and stage mountings can be customized to suit a wide range of applications from microscopy, to hard disk testing and semiconductor inspection.



Key Features

- >500µm travel with nanometer-level resolution
- Ultra-low rotation errors: 0.0025°
- Capacitive positioning sensor providing unrivalled position precision and accuracy. 2nm resolution and 5nm repeatability
- Typically <0.002% linearity error
- Dynamic performance: unloaded resonant frequency typically 210Hz and servo loop bandwidths up to 55Hz
- In-situ scanning and step response optimization
- Plug and Play: stage connector containing the stage calibration data and reference sensor allowing easy controller interchangeability

Typical Applications

- High precision microscopy:
 - Confocal
 - Light sheet
- Hard disk inspection
- Semiconductor inspection and manufacture
- Scientific and medical instrumentation
- Mirror positioning

Technical Specification

The measurements were taken at the tip of a cantilevered load, providing specifications relevant to likely applications. Where the load is position at the centre of the stage, performance will be improved.

Parameter	Value			Units	Comments
Static physical					
Material	Aluminum (Nickel plated) & Austentic Stainless				
Size	35.5 x 60 x 24.5			mm	
	Minimum	Typical	Maximum		
*Range Open Loop	550	650		μm	
*Range Closed Loop		500		μm	
Static stiffness		0.135		N/μm-1	
*Resonant frequency: 0g load		210		Hz	
*Resonant frequency: 20g load		195		Hz	
Resonant frequency: Maximum load			1	Kg	Note 1
Dynamic physical (Typical values)					
	Slow	Medium	Fast		Note 2
*3dB Bandwidth			55	Hz	Typical
*Small signal settle time			10	ms	Note 3
*Position noise (1σ) / Resolution	2		5	nmm	Note 4
Repeatability (Half range)	5			nm	Note 5
Error terms					
	Minumum	Typical	Maximum		
*Linearity error (peak)		0.02		%	Note 6
*Rotational error roll		0.0025		deg	Note 7
*Rotational error pitch		0.0025		deg	Note 7
*Rotational error yaw		0.005		deg	Note 7

Notes

*These parameters are measured and supplied with each mechanism

1. Loads greater than 250 g should be discussed at the point of purchase.
2. For dynamic operation the servo-loop parameters are preset for different performances; the parameters are user settable via software control. Fast means the fastest the stage can move for all masses up to the maximum allowed mass – equivalent to low noise setting.
3. Step and Settle time is the time taken to settle to within 2% of the step measured using an interferometer. The step settle time is a function of the servo loop parameters which are user controllable.
4. The actual position noise of the stage measured using an interferometer sampling 1 Hz to 25 kHz.
5. 1σ value.
6. Percent of the displacement.
7. Angular motion over the full range of the stage. These rotational errors are rotational errors around the Z, Y and X axes respectively

Sample Holders

Custom sample holders can be designed for your application.



35mm Petri Dish Holder mounted on the stage.



Single Slide Holder



35mm Petri Dish Holder

NPC-D-6110 Controller



- The powerful digital controller drives the SP Mini-500 at the fastest speeds possible.
- Motion control algorithms with acceleration/ deceleration control and active damping reduce overshoot.
- Velocity control algorithm gives ultra-smooth ramps for applications such as focus stacking or focus bracketing.
- Market-leading 20 μ s update rate
- Fastest recovery time between z-stacks, providing enhanced time resolution
- Selectable tuning presets which optimize for step settle or sample mass (for example, incubator).

Interfacing

- Analog command input and position output (0-10 V) for compatibility with existing systems.
- Digital commands over USB for maximum accuracy with a DLL interface for customer software. In-position digital outputs can be used to control camera imaging by providing rapid z-stacking.
- Digital quadrature/step-and-direction commands allow high-speed control with a standard 2-wire motion controller interface, without the need for expensive high-precision ADCs/DACs.
- Playback of custom-programmed waveforms such as constant-velocity profiles. Separate digital trigger outputs can be activated at custom-defined points to control external equipment such as camera imaging.
- Compatible with Queensgate Nanobench, Micro-Manager, Metamorph, Elements via RS232C, and other customer software using the DLL interface provided.
- Can be connected to Prior ProScan III for integrated fine z-control.

Installation information

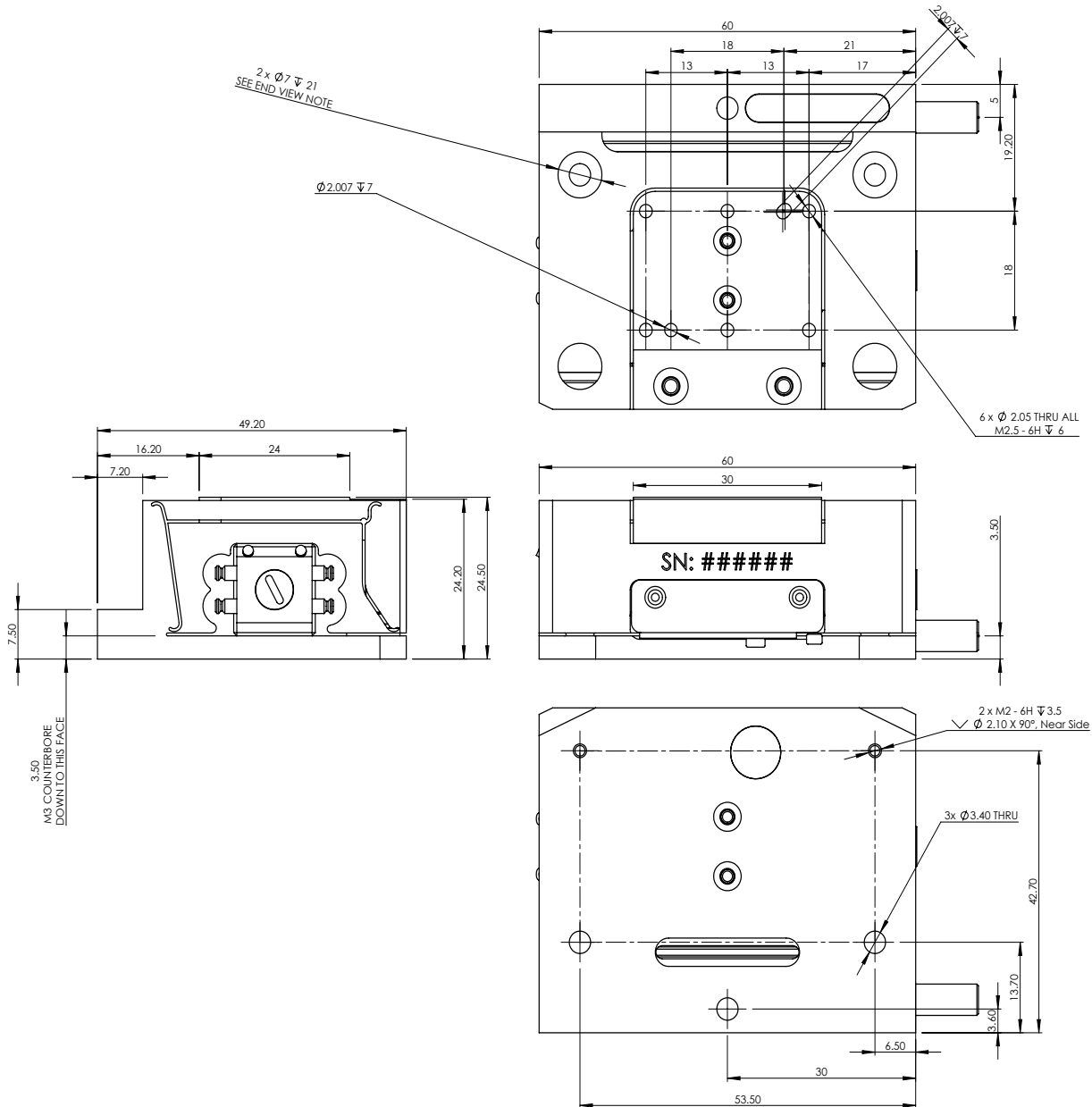

UNITED KINGDOM

Prior Scientific Instruments Ltd.
Units 3-4 Fielding Industrial Estate
Wilbraham Road, Fulbourn
Cambridge, CB21 5ET
United Kingdom
Email: inquiries@prior.com
Phone: +44 (0)1223 881711

U.S.A.

Prior Scientific, Inc.
80 Reservoir Park Drive
Rockland, MA. 02370
U.S.A.
Email: info@prior.com
Phone: +1 781.878.8442

GERMANY

Prior Scientific Instruments GmbH
Maria-Pawlowna-Str. 4
D-07743, Jena, Germany
Email: jena@prior.com
Phone: +49 (0) 3641 24 20 10

JAPAN

Kayabacho 3rd Nagaoka Bldg 10F,
2-7-10, Nihonbashi Kayabacho, Chuo-Ku,
Tokyo103-0025, Japan
Email: info-japan@prior.com
Phone: 03-5652-8831

CHINA

Prior Scientific Instruments (Suzhou) Ltd.
Room 1812, Honghai Building,
72 Xingdu Street, Suzhou Industrial Park,
Suzhou, 215000 China
Email: info-china@prior.com
Phone: +86 (0)512 6617 5866



FM 61600